

► **Description**

Wall hung, wall outlet, Waterfree Vitreous China Urinal.

► **Features**

- Touch-free operation
- Uses no water
- Mechanical-free design
- Patented, Sealed Locking Cartridge
- Smooth, non-porous surfaces

► **Benefits**

- Improved hygiene and safety
- Reduced water and sewer costs
- Water supply piping not required
- Odor-free
- Vandal resistant
- Minimal care and easy cleaning

► **Specifications**

Wall hung, wall outlet, waterfree, Vitreous China Urinal with the following features:

- Vitreous China Fixture
- Cartridge Housing (H-1, Mod. 3)
- Cartridge Kit † — Engineered to last for an average of 7000 uses
- One piece Wall Bracket with Anchors Included
- Uni-coupler (for new and retrofit installations)
- Drain Line Test Cap

† Additional Cartridges sold separately

► **Colors**

Standard White

Consult factory for optional colors.

► **Cartridge Filter**



Patented, Sealed Cartridge uses a Biodegradable Sealant Liquid to control odors.

The patented Cartridge is engineered to last for an average of 7000 uses and to receive waste through drain holes. Waste passes through an immiscible layer of biodegradable Sealant, continues through a Trap System, and flows over a Baffle to prevent the loss of Sealant. A Discharge Tube in the housing directs the flow of waste into the building drain system. The Cartridge is designed as a replaceable component when its function has been exhausted.



Featuring Falcon Waterfree Technology



**The New Sloan Waterfree Urinal —
Preserves our Natural Resources and
saves costs**

Sloan Waterfree Urinals reduce water and sewer costs, maintenance and repair bills, and create more hygienic, odor-free restrooms. A Patented, Sealed Cartridge eliminates the need for water, typically conserving 40,000 gallons per unit per year. Installing Waterfree Urinals along with other Sloan Conservation Products ensures meaningful water savings. In addition, Sloan Waterfree Urinals do not require costly supply piping to fixture.



This space for Architect/Engineer approval	
Job Name _____	Date _____
Model Specified _____	Quantity _____
Variations Specified _____	
Customer/Wholesaler _____	
Contractor _____	
Architect _____	

- ▶ **Description**
Wall hung, wall outlet, Waterfree Vitreous China Urinal.
- ▶ **Dimensions**
24⁵/₈" (625 mm) x 16⁷/₈" (429 mm) x 14⁵/₈" (371 mm)
- ▶ **Approximate Weight**
43 lbs.
- ▶ **Mounting For ADA Compliance**
For lip height of 17" (432 mm), distance from finished floor to drain centerline must be 9⁵/₈" (244 mm).

Uni-Coupler
The Uni-coupler connects the urinal housing to the building drain system and conforms to NSF 14 for plastic pipes and fittings. It is designed for use in both new and retrofit applications and offers a variety of configurations to meet most existing drain openings.

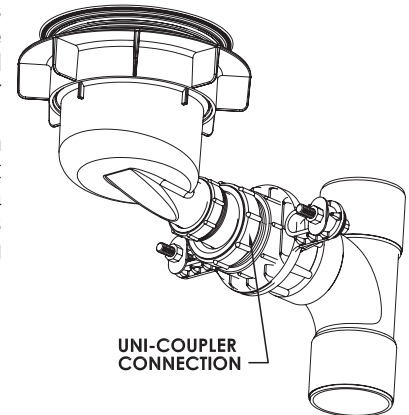

ROUGH-IN

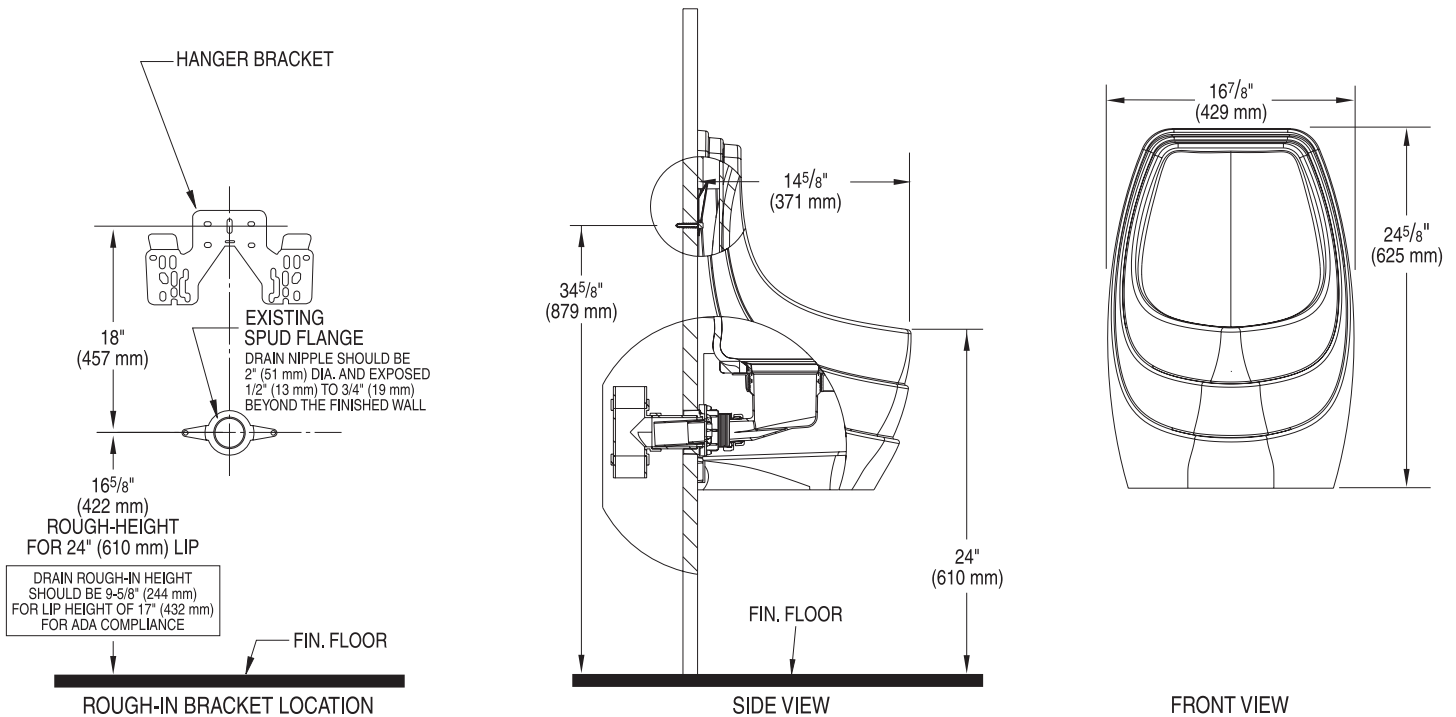

MAINTENANCE AND CLEANING

- Perform cleaning once a day, or as needed
- Remove any litter in the bowl and clear cartridge drain slots
- Use mild disinfectant cleaner on a cloth to wipe the bowl
- DO NOT use aggressive/concentrated detergents or any other chemicals
- DO NOT dispose of water into the urinal

SLOAN VALVE COMPANY • 10500 SEYMOUR AVENUE • FRANKLIN PARK, IL 60131

Phone: 1-800-9-VALVE-9 or 1-847-671-4300 • Fax: 1-800-447-8329 or 1-847-671-4380 • <http://www.sloanvalve.com>